





# MB400

# XLline

-  M&B MB400 is the computerized electronic balancing machine that combines enhanced performance with reduced size
-  M&B MB400 è l'equilibratrice elettronica computerizzata che unisce prestazioni avanzate a ingombri contenuti
-  M&B MB400 est l'équilibruse électronique informatisée qui unit des performances avancées à des encombrements contenus
-  M&B MB400 ist das computergesteuerte elektronische Auswuchtgerät das fortschrittliche Leistung mit kleinen Abmessungen kombiniert
-  M&B MB400 es la equilibradora electrónica computerizada que une prestaciones avanzadas a un tamaño reducido



	WHEEL GUARD	GRAPHIC INTERFACE	DISTANCE AND DIAMETER MEASURING	WIDTH MEASURING	WHEEL LOCKING	ELECTROMAGNETIC BRAKE	LASER LINE
<b>MB400</b>	Standard	17" TFT flat screen	with automatic gauge	with Virtual Sonar	Manual	Standard	Standard

## STANDARD CONFIGURATION



# OPTIONAL ACCESSORIES

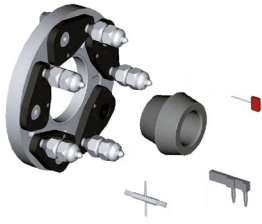

**UH20/2 Ø 40**  
Universal adapter 3-4-5-6 hole



**RL cup Ø 40**  
with rubber ring for alloy rims protection

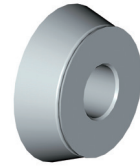

**J cone Ø 40**  
for cross-country and  
4WD wheels range Ø 101÷119 mm

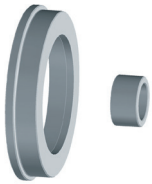

**WD spacer Ø 40**  
(Spacer for wide wheels) + DC spacer  
Ø 40 (to use together with WD)



**VL/2 cone Ø 40**  
Large cone for light truck 97÷180 mm



**Special cone Ø 40** for central  
hole Ø 89/132 mm



Professional automatic wheel lift  
capacity 80 kg

## OVERALL DIMENSIONS

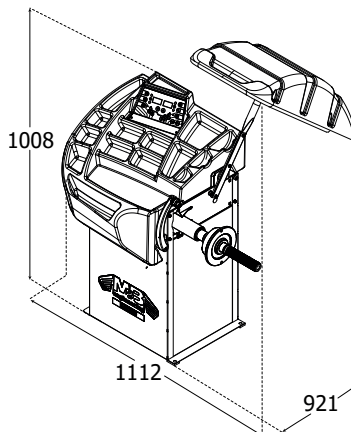

**MB300/MB330 XL**

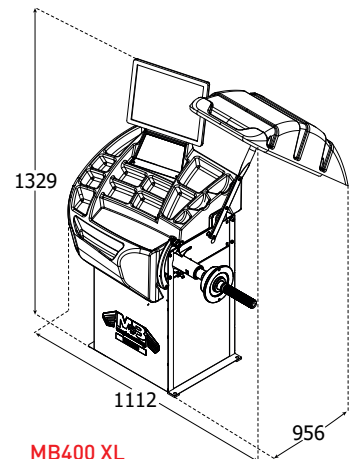

**MB400 XL**

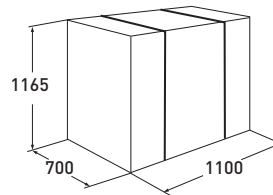

## TECHNICAL DATA

110 kg	10" ÷ 30" 265 ÷ 765 mm	1.5" ÷ 20" 40 ÷ 510 mm	20" 508 mm	40" 1120 mm	< 75 kg	230V/1/50-60 Hz 115V/1/60 Hz	100 rpm	0,15



**M&B ENGINEERING SRL**  
Via Nobel, 21 - 42124 Reggio Emilia (RE)  
info@mb-re.it - www.mbenengineering.info